

The first view camera
specifically designed for digital photography.

Cambo Ultima

"The Ultima's movements are extremely precise and finely geared which are critical for digital photography. Because the digital chip is so small, every tiny camera move makes a big difference while focusing. I used to fight traditional view cameras to get that kind of precision. The Ultima is a fabulous piece of equipment."

Russell Fichter,
Quebecor Imaging Chicago
Schaumburg, Illinois U.S.A.



Photo by Russell Fichter/Quebecor Imaging Chicago

Cambo Ultima

Tomorrow's Technology for Today's Digital Studio

CAMBO ULTIMA

After closely examining the view cameras in today's market, Cambo discovered that there wasn't a single camera designed specifically for the highly sensitive requirements of focusing on such a small "chip" plane, digital imaging requires the extremely tight tolerances of ultra-fine camera movements. In order to fill this increasingly critical void, Cambo created the Ultima.

As its name implies, the Ultima offers the ultimate in precision image control for both digital and traditional large format photographers. Cambo's newest view camera represents an entirely new and distinctive design created for high performance, maximum flexibility, and pinpoint accuracy.

The Ultima's compact, symmetrical shape and sleek, aluminum construction provide utmost stability, while its fluid-smooth, geared movements, progressive brakes and positive position locks instill a sense of precision and fingertip control.

Cambo designers have incorporated numerous special features beneficial to today's digital photographer, including a revolutionary "depth adjustment" which allows the user to position the digital chip of all backs precisely where it needs to be for maximum performance. This unique movement makes the Ultima universally compatible with all digital scanning backs, including MegaVision, Better Light, Leaf and Eyelike.

FEATURES:

- Full range of movements suitable for both traditional and digital
- Precision-gearred fine focus, rise and fall, tilt, swing and shifts
- Dual range focusing for rapid coarse and precision fine focusing
- Depth of field scale
- Zero-position detents with definite end stops
- "Virtual Pivot" design for fully yaw-free variable axis tilts
- Individual locks on coarse and fine focus, rise and fall movements
- Symmetrical design on front and rear standards for easier operation
- High-quality aluminum body with durable metallic finish
- Extremely rigid compact design
- Converts easily and economically, to 8x10" and 2 1/4" roll film format view cameras
- Unique design allows for use of lenses down to 47mm — without requiring a recessed lensboard

Cambo Ultima D

Created for digital applications. Includes wide angle bellows, short monorail and tripod mounting block.

Cambo Ultima

Includes standard bellows, split monorail, adjustable tripod mounting block and ground glass back.

UNIQUE BENEFITS FOR ENHANCED DIGITAL PERFORMANCE:

- Unique film, or chip plane "depth adjustment" allows precise alignment of chip plane, preventing the center of the image from moving out of focus when swing or tilt movements are applied
- Rigidly designed base tilt mechanism provides an extremely stable platform for heavy digital backs
- Compact shape and self-locking rise and fall movement allow for even the heaviest of digital backs to be used effectively
- Tight tolerances on precision gearing, specially when focusing on small chips

ULTIMA ACCESSORIES

- Flat Lensboards*
 - Recessed Lensboards*
 - 15cm Extension Rail
 - 30cm Extension Rail
 - Rail Clamp
 - Wide Angle Bellows
 - Binocular Viewing Hood
- *specify shutter size

MORE ACCESSORIES

See pages 11-15

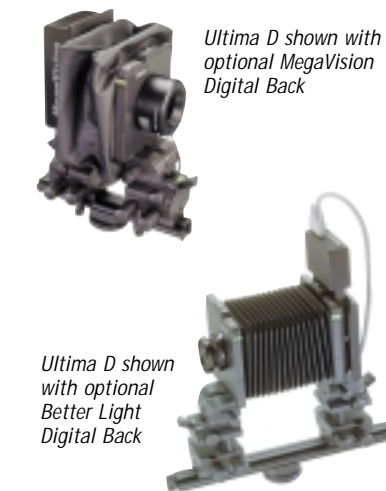
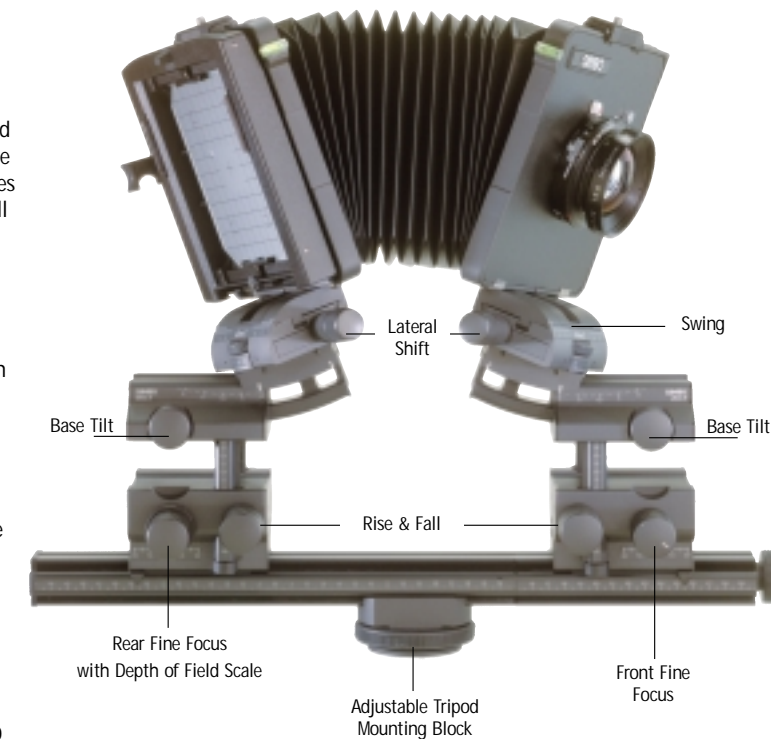

Ultima Specifications

Monorail length:
300mm for digital
450mm for film
Tilts: $\pm 20^\circ$ front & rear
Swings: $\pm 30^\circ$ front & rear
Rise & Fall: ± 20 mm front & rear
Lateral Shifts: ± 25 mm
Weight: 6 kg / 13.2 lbs

For detailed specifications on the Ultima camera, please turn to page 9.

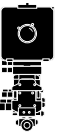

Cambo Sliding Back

This convenient "sliding back" allows you to view through the ground glass and slide your film or digital back into place. Adapts to most digital backs and many popular roll film backs. Optional adapter required.

Sliding Back Adapters & Masks

- Hasselblad Adapter
- Mamiya RB Adapter
- Mamiya RZ Adapter
- Mamiya 645 Adapter
- Contax 645 Adapter

Sliding Back Masks

- For 24x36 CCD Back
- For 31x31 CCD Back

